

MR-4TCSD

TYPE: CGM

SETTING SHEET

CIRCUIT

- ENVIRONMENT ➔ Indoor ➔ Outdoor
 SURFACE ➔ Asphalt ➔ Concrete ➔ Carpet
 GRIP ➔ High ➔ Regular
 CONDITION ➔ Flat ➔ Bumpy

DRIVER _____

DATE _____

FRONT

- DRIVETRAIN ➔ One-way
 ➔ Ball diff
 ➔ Solid
 ANTI-ROLL BAR ➔ None
 ➔ Upper
 ➔ Lower
 ➔ _____ mm
 HUB CARRIER ➔ _____ deg
 CAMBER ➔ _____ deg
 TOE ANGLE ➔ _____ deg
 FRONT KICK-UP
 ➔ _____ deg
 SUSP. MOUNT HEIGHT SPACER
 (front & rear) ➔ _____ mm
 STEERING KNUCKLE
 ➔ Inline
 ➔ 0.5mm offset
 ➔ 1mm offset

- BLADDER ➔ _____
 PRESSURE ➔ _____
 SHOCK BODY ➔ SSS
 ➔ SS
 SHOCK END ➔ Long
 ➔ Short
 ➔ _____ mm
 LENGTH ➔ _____ mm
 SPRING ➔ _____
 OIL ➔ _____
 PISTON ➔ _____

CAMBER LINK & SHOCK MOUNTING POSITION

STEERING KNUCKLE

- ➔ Standard
 ➔ Graphite
 CASTER BLOCK
 ➔ Standard
 ➔ Graphite

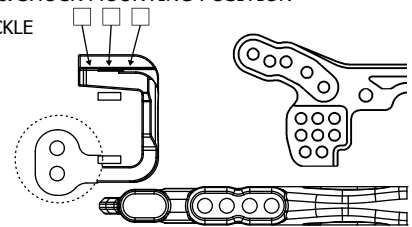

LOWER SUSPENSION ARM POSITION

LOWER SUSPENSION ARMS

- ➔ Standard
 ➔ Graphite

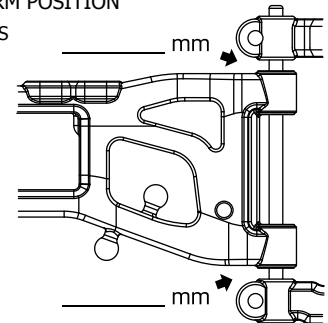

DROOP HEIGHT

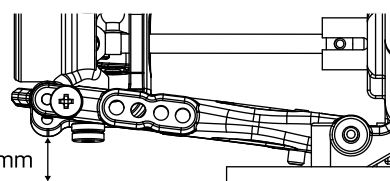

REAR

- ANTI-ROLL BAR ➔ None
 ➔ Upper
 ➔ Lower
 ➔ _____ mm
 CAMBER ➔ _____ deg
 SUSP. MOUNT TOE ANGLE
 ➔ 1 deg
 ➔ 2 deg
 ➔ 3 deg
 REAR ANTI-SQUAT
 ➔ _____ deg
 SUSP. MOUNT HEIGHT SPACER
 (front & rear) ➔ _____ mm
 REAR HUB CARRIER
 ➔ 0 deg
 ➔ 0.5 deg
 ➔ 1 deg

- BLADDER ➔ _____
 PRESSURE ➔ _____
 SHOCK BODY ➔ SSS
 ➔ SS
 SHOCK END ➔ Long
 ➔ Short
 ➔ _____ mm
 LENGTH ➔ _____ mm
 SPRING ➔ _____
 OIL ➔ _____
 PISTON ➔ _____

CAMBER LINK & SHOCK MOUNTING POSITION

REAR HUB CARRIER

- ➔ Standard
 ➔ Graphite

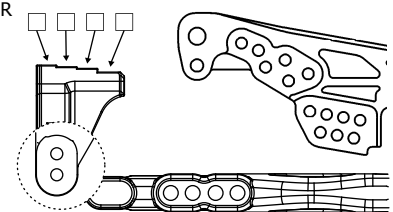

LOWER SUSPENSION ARM POSITION

LOWER SUSPENSION ARMS

- ➔ Standard
 ➔ Graphite

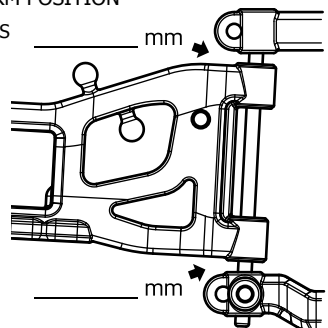

DROOP HEIGHT

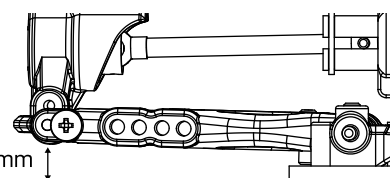

OTHER

- TIRE ➔ _____
 INSERT ➔ _____
 WHEEL ➔ _____
 TRACTION ADDITIVE
 ➔ None
 ➔ _____
 SPUR GEAR ➔ _____P_____T
 PINION GEAR ➔ _____P_____T
 GEAR RATIO ➔ _____ : 1
 = spur gear / pinion gear x 2.35 (internal drive ratio)
 RIDE HEIGHT ➔ F _____ mm
 ➔ R _____ mm

- MOTOR ➔ _____
 BATTERY ➔ _____
 ESC ➔ _____
 FRONT BODY POST POSITION
 ➔ Inner
 ➔ Outer
 BODY ➔ _____
 WING ➔ _____

- TRANSMISSION CASES
 ➔ Standard
 ➔ Graphite
 FRONT SUSPENSION MOUNTS
 ➔ Standard
 ➔ Aluminum
 REAR SUSPENSION MOUNTS
 ➔ Standard
 ➔ Aluminum

COMMENT
